

THERMO-ANEMOMETER TEST INSTRUMENT

Measures Air Velocity or Air Volume and Temperature Simultaneously

CALIBRATION SERVICES AVAILABLE



New six button operation provides quick access to enhanced features

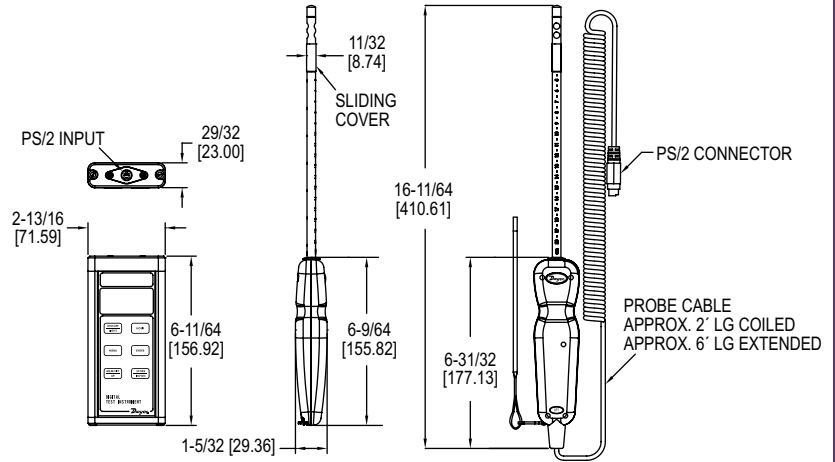

The **Model 471B Thermo-Anemometer Test Instrument** is a versatile dual function unit that quickly and easily measures air velocity or volumetric flow as well as air temperature in imperial or metric units. A stainless steel probe is included, which has a comfortable hand grip and etched insertion depth marks. The extruded aluminum housing fully protects electronics, yet is lightweight and comfortable to hold.

BENEFITS/FEATURES

- Compatible with Dwyer RP1 thermo-hygrometer and VP1 100 mm vane thermo-anemometer probes (sold separately)
- Visible in any condition due to high contrast and backlit LCD display
- Able to store up to 99 readings
- Probe sensors are protected by the integral sliding cover
- Built-in volumetric air flow calculations

APPLICATIONS

- Duct traverses
- HVAC inspections
- Testing and balancing

MODEL CHART	
Model	Description
471B-1	Digital thermo anemometer includes 9 V battery, sensing probe, wrist strap, soft carrying case and instructions

OPTIONS	
Model	Description
-NIST	NIST traceable calibration certificate

ACCESSORIES - PROBES		
Model	Probe Length	Description
AP1	8"	Thermo anemometer air velocity and temperature probe with coiled cable
AP1-18	18"	Thermo anemometer air velocity and temperature probe with coiled cable
AP1-24	24"	Thermo anemometer air velocity and temperature probe with coiled cable
AP1-36	36"	Thermo anemometer air velocity and temperature probe with coiled cable

SPECIFICATIONS
Service: Air velocity and temperature of clean, dry air.
Temperature Limits: Process air velocity: -20 to 212°F (-29 to 100°C); Process temperature: -40 to 212°F (-40 to 100°C); Ambient: 5 to 125°F (-15 to 51°C).
Display: 4.5 digit LCD.
Resolution: 0.1%, 0.1°F/°C.
Air Velocity Range: 45 to 6000 FPM (0.23 to 30 m/s).
Air Velocity Accuracy: ±3% FS within temperature range of 40 to 90°F (4 to 32°C). -TAB option: ±5% of reading, not less than ±1.6 FPM (0.5 m).
Volumetric Air Flow Range: 19,999 in selected flow units.
Temperature Range: -40 to 212°F (-40 to 100°C).
Temperature Accuracy: ±0.5°F (±0.28°C) from 32 to 122°F (0 to 50°C); ±1.5°F (±0.83°C) from -40 to 32°F (-40 to 0°C) & 122 to 212°F (50 to 100°C).
Probe Length: 8" (203 mm) insertion.
Cable Length: 28" (71 cm) retracted, 6 ft (183 cm) extended.
Power Requirements: 9 V alkaline battery, installed non-functional, user replaceable.
Weight: 16 oz (454 g).
Agency Approvals: CE.



Replaceable probe with secure 6 pin adaptor



A-47X-BOOT (manometer not included)

ACCESSORIES - CASES	
Model	Description
A-160-CASE	Hard carrying case for longer probes (18" to 36")
A-47X-BOOT	Protective magnetic rubber boot

Thermo-Anemometers